



RCMS2201/2401/2601-60 (REV.A)

**Modular Ethernet Multiplexer
User Manual**

Cautions



Please read the following notices carefully before installing and using the device, Raisecom does not respond to any loss that caused by violating safety notice.



RCMS2201-30 is integrated device that has precise elements, please avoid violent shakes and impacts, and do not disassemble or maintain the device yourself. If it is required, please do it under the guide of our technical staff following in the steps of anti static. Please contact us if there is any need.



There must be grounding protection for the sake of safety; do not disassemble the device yourself, we regard it as you waiver your rights of repair guarantee.

Contents

1. Overview	1
1.1 Main Features	1
1.2 Part Number Explanation	2
2. Parameters	2
2.1 E1 Interface Specification	2
2.2 Fast Ethernet Interface Specification	3
2.3 Optical Interface Specification	3
2.4 Ambience	3
3. How to use	3
3.1 Description of the Front Panel	3
3.2 Dip-switch	4
3.2.1 SW1 for Working Modes	4
3.2.2 Fault-Pass-Through Capability Explanation	5
3.2.3 E1 Remote Loop-back Test	6
3.2.4 How to Implement Remote Network Management	6
4. Installation and Test	7
4.1 Inspect after Opening	7
4.2 Preparation before Installation	7
4.3 Installation	7
4.3.1 Connecting the Cables	7
4.3.2 Function Configuration	8
5. Troubleshooting	8
6. Appendix A Cable Making	9
A.1 E1 Cable Making	9
A.2 Ethernet Cable Making	10

1. Overview

RCMS2201/2401/2601-60 Ethernet Multiplexers are fiber-optic transmission devices for dedicated communication networks, data communication networks, switching networks, and also for point-to-point networks, medium-sized and small capacity networks. It can multiplex one E1 channel and one Fast Ethernet on to one fiber-optic cable, and implement the line-speed transmission of the Ethernet data. RCMS2201-60、RCMS2401-60 和 RCMS2601-60 series is featured by high integration and complete network management functions. It can be installed into the Raisecom 3U-high 16-slot chassis, or desktop single-slot chassis, providing various network management functions.

Include the following models:

Model	Description
RCMS2201-60-M	Host-site/remote-site module, 1 10/100Mbps auto-sensing (RJ45), 2 120ohm balanced E1 (RJ45), multimode (DSC), 0~2km
RCMS2201-60-S1	Host-site/remote-site module, 1 10/100Mbps auto-sensing (RJ45), 2 120ohm balanced E1 (RJ45), single mode (DSC), 0~25km
RCMS2201-60-S2	Host-site/remote-site module, 1 10/100Mbps auto-sensing (RJ45), 2 120ohm balanced E1 (RJ45), single mode (DSC), 10~60km
RCMS2201-60-S3	Host-site/remote-site module, 1 10/100Mbps auto-sensing (RJ45), 2 120ohm balanced E1 (RJ45), single mode (DSC), 15~120km
RCMS2401-60-S1	Host-site/remote-site module, 1 10/100Mbps auto-sensing (RJ45), 2 120ohm balanced E1 (RJ45), single mode, single strand fiber, dual wavelength, 1310nmTx 1550nmRx (SC-PC), 0~25km
RCMS2401-60-S2	Host-site/remote-site module, 1 10/100Mbps auto-sensing (RJ45), 2 120ohm balanced E1 (RJ45), single mode, single strand fiber, dual wavelength, 1310nmTx 1550nmRx (SC-PC), 10~60km
RCMS2601-60-S1	Host-site/remote-site module, 1 10/100Mbps auto-sensing (RJ45), 2 120ohm balanced E1 (RJ45), single mode, single strand fiber, dual wavelength, 1550nmTx 1310nmRx (SC-PC), 0~25km
RCMS2601-60-S2	Host-site/remote-site module, 1 10/100Mbps auto-sensing (RJ45), 2 120ohm balanced E1 (RJ45), single mode, single strand fiber, dual wavelength, 1550nmTx 1310nmRx (SC-PC), 10~60km

1.1 Main Features

- Low power consumption due to extra large-scale ASIC chips; high reliability due to 4-layer PCB
- Providing 2 E1 channel interface, transparent transmission mode

- Providing 1 10/100Mbps auto-sensing Ethernet interface
- Providing 1 optical interface, multiplexing E1 and Ethernet data together
- Alarm indications of local and remote equipment
- Supporting E1 link remote loop-back function, easy fault location
- Supporting speed limit on both transmitting and receiving directions of Ethernet interface, increment 32kbps
- Implementation of SNMP, capable of local and remote management

1.2 Part Number Explanation

Example_

RC MS 2 2 01 - 60 - S2

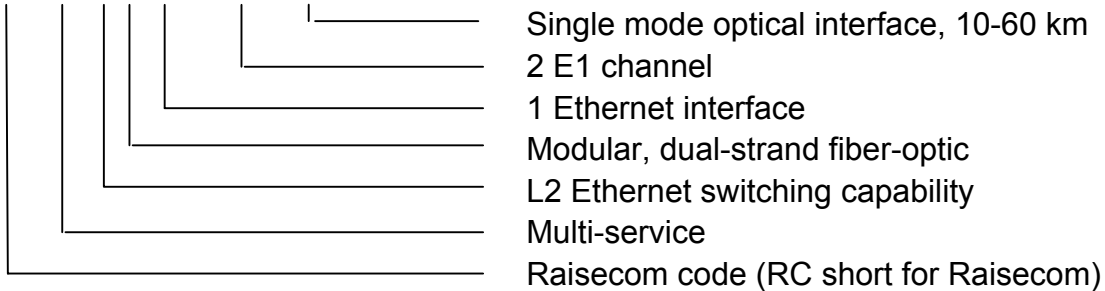

Note: Equipments that can work in pairs

	Host site	Remote site
Dual-strand fiber-optic equipment	RCMS2201-60-M	RCMS2201-60-M
	RCMS2201-60-S1	RCMS2201-60-S1
	RCMS2201-60-S2	RCMS2201-60-S2
	RCMS2201-60-S3	RCMS2201-60-S3
Single-strand fiber-optic equipment	RCMS2401-60-S1	RCMS2601-60-S1
	RCMS2401-60-S2	RCMS2601-60-S2

2. Parameters

2.1 E1 Interface Specification

Bit rate:	2048Kbps±50ppm
Line code:	HDB3
Interface impedance:	120Ω balanced signal
Electrical characteristic:	Compliant to ITU-T G.703
Transfer characteristic:	Compliant to ITU-T G.823
Jitter Tolerance:	ITU-T G.724

2.2 Fast Ethernet Interface Specification

IEEE 802.3

IEEE 802.3u

IEEE 802.1d Spanning Tree

IEEE 802.1q VLAN

Support oversized Ethernet data frame up to 1916 bytes

Working mode: 10/100M Auto-Negotiation, Auto-MDI/MDIX (manual configurable)

Flow control: IEEE802.3x and back pressure

2.3 Optical Interface Specification

Bit rate: 150Mbps

Fiber connector: Dual-strand fiber DSC/APC

Single strand fiber SC/PC

Transmission distance: Multimode dual-strand M=0 ~2km

Single mode, dual-strand fiber, S1=0~25 km, S2=10~60km,
S3=15~120km

Single mode, single strand fiber, S1=0~25 km, S2=10~60km

2.4 Ambience

Working temperature: 0 ~ 45°C

Relative humidity: ≤ 90% (25°C)

3. How to use

3.1 Description of the Front Panel

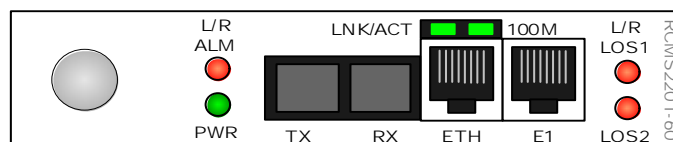

Power Supply Indicator:

PWR (Power): the green indicator will be lightened when the power supply is in good condition

Optical Connector:

SC type in the above figure, TX for transmitting direction, and RX for receiving direction
 The optical interface type of RCMS2201-60 is DSC/PC,
 The optical interface type of RCMS2401-60 and RCMS2601-60 is SC/PC.

L/R ALM (Fiber Local or Remote Alarm)

The red alarm indicator will be lightened when error occurs at local or remote optical receiving direction. It includes 4 alarm levels: lose of signal, lose of frame, BER exceeds 10^{-3} , and BER exceeds 10^{-6} . Users shall inquire the network management system for alarm details.

ETH Ethernet Interface:

RJ45 socket, unshielded twisted pair

LNK/ACT (Link/Action):

The green indicator will be lightened when the link is in normal condition. It flashes when transmitting to receiving data.

100M (100Mbps):

The green indicator will be lightened when working at the rate of 100Mbps.

E1 Interface:

RJ45 socket, 120 Ohm balanced signal.
 Pin 1, 2 for output of first E1 channel, pin 5, 6 for input of first E1 channel
 Pin 3, 4 for output of second E1 channel, pin 7, 8 for input of second E1 channel

L/R LOS1 (Local/Remote Lose Signal of first E1)

E1 alarm of first E1 channel, the red alarm indicator will be lightened when E1 input loss of frame occurs at the local site; it flashes when E1 input loss of frame occurs at the remote site. There is no alarm, when no E1 input loss of frame of local and remote site.

L/R LOS2 (Local/Remote Lose Signal of second E1) :

E1 alarm of second E1 channel, definition is same as above.

3.2 Dip-switch

3.2.1 SW1 for Working Modes

SW1 is an 8-bit DIP-switch, as the figure on the right

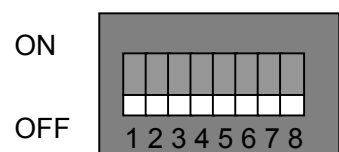

Switch	OFF (default status)	ON
1	Enable Ethernet interface auto-sensing	Disable Ethernet interface auto-sensing
2	a) Ethernet forced 100M when auto-sensing disabled b) Invalid when auto-sensing enabled	a) Ethernet forced 10M when auto-sensing disabled b) Invalid when auto-sensing enabled
3	a) Ethernet forced full duplex when auto-negotiation disabled b) Ethernet forced full duplex when auto-negotiation failed; invalid when auto-negotiation success	a) Ethernet forced half duplex when auto-negotiation disabled b) Ethernet forced half duplex when auto-negotiation failed; invalid when auto-negotiation success
4	Fault Pass Through disabled	Fault Pass Through enabled
5	Enable MDI/MDIX auto-negotiation	Disable MDI/MDIX auto-negotiation. Straight-through cable shall be used to connect to Switch; crossover cable shall be used to connect to NIC and Routers
6	First E1 link normal working mode	First E1 link remote loop-back
7	Second E1 link normal working mode	Second E1 link remote loop-back
8	Auto recognition of network management channel	Forced remote network management. Please configure as per the network topology.

Priority of configuration and command of network management software is higher than configuration of SW1. Configuration of SW1 is invalid when using network management software to configure.

Note: The other dip-switch SW2 is a 2-bit switch, which shall be used by manufacturing people. Users are not advised to change the default status.

3.2.2 Fault-Pass-Through Capability Explanation

When Fault-Pass-Through capability is enabled, there are 3 situations that we call it a link fault.

1. The equipment will monitor the status of remote Ethernet interface. When it changes to link down from link up, we take it as a link fault of remote Ethernet. At the same time, the status of local module will change to link down from link up. It will not be recovered until the fault disappears at remote site.
2. The equipment will monitor the status of remote E1 interface. When it changes to loss of signal status from normal, we take it as a link fault of remote E1 link. At the mean time, the equipment will cut off the transmission of local E1 interface but not send AIS signal. The local E1 interface will not recover until the fault disappears at

remote site.

- The equipment will monitor the status of optical link, either transmitting alarm or receiving alarm will be taken as an optical link fault. At the mean time, the Ethernet interface status will change to link down and the E1 interface will be cut off. The Ethernet interface and E1 interface will not recover until the optical interface recovers.

The fault-pass-through capability is designed for users who have particular requirements. When it is disabled, any fault at remote site and at optical interface has nothing to do with local interfaces; all the interfaces of local module will be open.

In order to avoid misunderstanding, users are advised to use it cautiously. The factory default status is disabled.

3.2.3 E1 Remote Loop-back Test

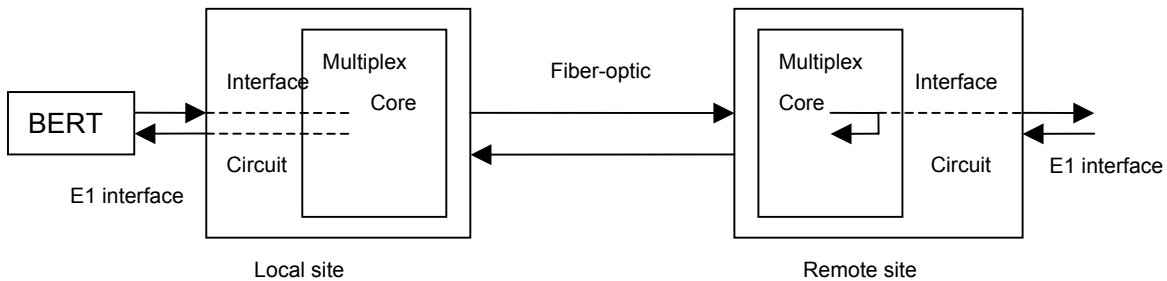

“E1 remote loop-back” setup at local Ethernet Multiplexer

Note: when setup any kinds of loop-back at the local Ethernet Multiplexer, the “remote loop-back” switch at remote Ethernet Multiplexer must be at default status.

When the module is at E1 remote loop-back status, the Ethernet data communication will not be interfered.

3.2.4 How to Implement Remote Network Management

When the equipment is connected as the following topology, the remote network management can be implemented.

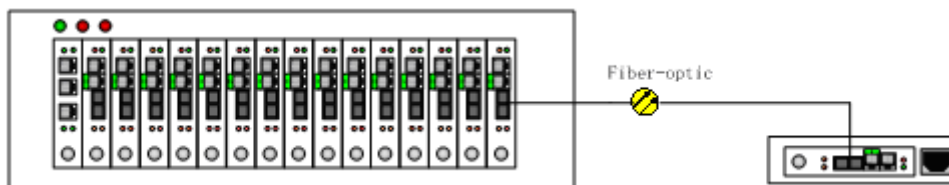

- The host-site module is installed in Raisecom’s dedicated 16-slot 3U-high chassis, which also has the network management module installed. The remote-site module is installed in Raisecom’s single slot chassis.

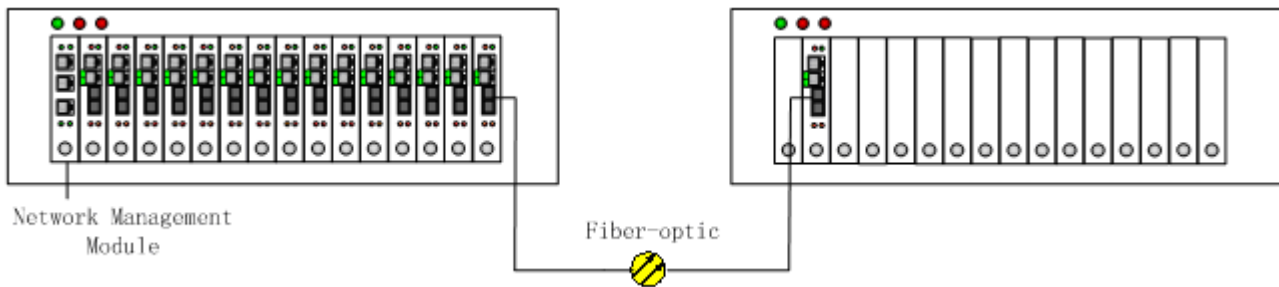

- B. The both modules are installed in 16-slot 3U-high chassis, but only the host-site chassis is equipped with network management module. The remote-site module shall be set to “forced remote network management mode”. That is to say, the 8th switch shall be turned to ON.

4. Installation and Test

4.1 Inspect after Opening

Please first check if the models and part numbers are in consistence, and also check if the equipments are damaged.

4.2 Preparation before Installation

- Carefully read this manual
- Prepare all kinds of the cable. Ensure that they are not short-circuited. Refer to Appendix A for cable making.
- Ensure the pressure of power supply is in the tolerance range, the chassis is well connected with the ground.
- Prepare the BERT and optical power meter for test of line quality.
- Place the equipment at stable and secure environment. Pay attention to the requirements of the ambience.

4.3 Installation

This module can be installed into Raisecom’s dedicated 16-slot 3U-high chassis, 4-slot 1U-high chassis, and single slot chassis. Slowly insert the module into the slot to the end, and fasten the fixing screw tightly.

4.3.1 Connecting the Cables

- E1 Interface:
RJ45 socket, 120 Ohm balanced signal.

Pin 1, 2 for output of first E1 channel, pin 5, 6 for input of first E1 channel
Pin 3, 4 for output of second E1 channel, pin 7, 8 for input of second E1 channel

- Ethernet Interface
Connect with Cat. 5 or hyper Cat. 5 twisted-pair cables. Either straight-through or crossover cable is OK.
- Optical Interface
Plug the tail fiber into the fiber socket to the end.

4.3.2 Function Configuration

After connecting the cables and applying the power supply, there shall not be alarms at the optical interface.

If users want to configure the dip-switches, first unplug the module from the chassis and then use a flat screw-driver to set switches.

5. Troubleshooting

If there is any problem during installation and operation, please try the following solutions. If the problem still cannot be solved, please contact distributors for technical support. The following explanations and solutions to optical and E1 LOS alarms are for the local module. If the alarms are at the remote site, please solve them at remote site.

- **Power (PWR) indicator (Green) is not ON**

Answer: Power supply fails. Check whether the power supply is working properly

- **LAL indicator (Red) at optical interface is ON**

Answer: Loss of signal at the optical interface. Check whether the input of optical fiber is connected properly. Users can test the optical power using optical power meter. The optical power shall be larger than the receiving sensitivity.

- **E1 sub-channel L/R LOS indicator (Red) is ON**

Answer: The local E1 sub-channel receiving signal is lost. If the indicator is flashing, it means the remote E1 sub-channel receiving signal is lost. Please check if the E1 interface is well connected.

6. Appendix A Cable Making

A.1 E1 Cable Making

Pin Number	1	2	3	4	5	6	7	8
Definition	OUT1+	OUT1-	OUT2+	OUT2-	IN1+	IN1-	IN2+	IN2-

When user needs balanced signal, modules can be connected to 120ohm balanced E1 interface of other equipment as per above table.

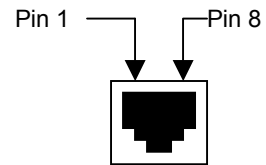

When user needs 75ohm unbalanced E1 interface, twisted-pair can be connected to E1 impedance converter. RC909-1E1 is single E1 channel impedance converter of Raisecom. Following is connecting figure of RCMS2201-60/ RCMS2401-60/ RCMS2601-60 and RC909-1E1

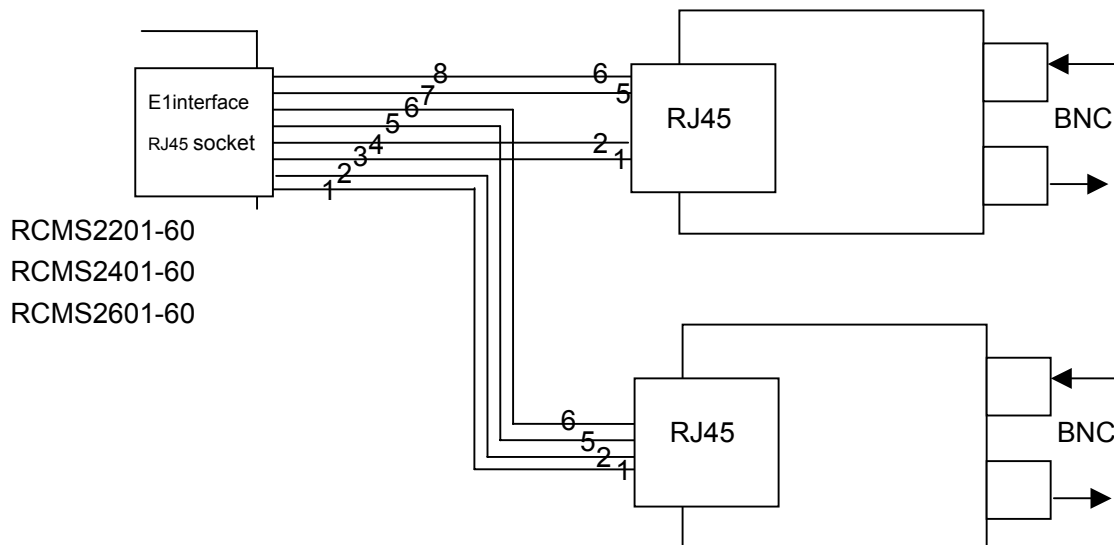

A.2 Ethernet Cable Making

Use Cat.5 twisted-pair cable with RJ45 connector to connect this equipment. Note that the cable shall not be longer than 100 meters.

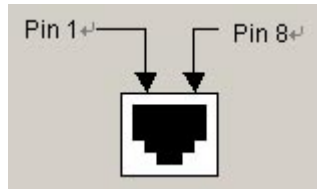

The cable can be either straight-through or crossover.

The sequence of the RJ45 connector is as follows.

Pin Number	1	2	3	4	5	6	7	8
MDI Definition	TX+	TX-	RX+	Not Used	Not Used	RX-	Not Used	Not Used
MDI-X Definition	RX+	RX-	TX+	Not Used	Not Used	TX-	Not Used	Not Used

BROADBAND to RAISECOM

@2005 Raisecom Technology Co., Ltd.

All trademarks are the property of their respective owners.

Technical information may be subject to change without prior notification.